

Manchester/V100/AdvantEdge/VuPoint Vinyl .5 Inch Structural Field Mull Installation Guide

IG-050 REV. 08/23 1.4

Not Available for Quartz Luxury.



Manchester V100 AdvantEdge VuPoint

Scan Here for a Digital Version of the
Installation Guides in English.

Quaker Residential Windows & Doors:
www.quakerresidentialwindows.com

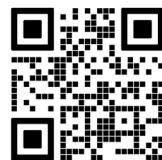

V100

Scan Here for a Digital Version of the
Installation Guides in English.

Quaker Commercial Windows & Doors:
www.quakercommercialwindows.com



Para ver las instrucciones en Espanol, escanea aqui.

If this set of instructions does not match your installation method or the wall conditions of the job site, please check our website listed below for other options, or call Quaker Customer Service for additional information.



Quaker Window Products
504 U.S. Hwy 63 South
Freeburg, MO 65035
(800) 347-0438
www.quakerwindows.com



PO Box 128

| 504 Highway 63 South

| Freeburg, MO 65035

| 800-347-0438

| 573-469-4151 (fax)

Installation Guidelines for all Quaker Vinyl products with Standard C-mull

Read these instructions completely before starting any installation. Failure to install and maintain our product according to these instructions may void any product warranty. Please visit our website at www.quakerwindows.com or call 1-800-347-0438 for additional information.



Tools required by installer:

Safety Glasses		Utility Knife	
Rubber Mallet		Caulk Gun	
Pliers		Tape Measure	

Materials required by installer:

Flashing Tape		Sealant	
Backer Rod			

Quaker Supplied Parts:

Jamb Filler (1111)		C-mull Key (D633)	
		Drip Cap (WRS-6236)	

WARNING

Tools

- Follow manufacturer's instructions for safe operation of tools, and ladders/scaffolding. Always wear safety glasses. Failure to do so could result in injury, product or property damage.

Handling

- Do not store units outside, or in a hot environment. Doing so could result in product damage.
- Do not carry flat.** Doing so could result in product damage, injury, or property damage.
- Stack units as straight as possible to avoid bowing. **Do not lay flat!**

Glass

- If broken, glass can fragment causing injury. All Quaker products are available with safety glass. In many areas, local building codes require safety glass in certain locations and/or applications. Unless safety glass is ordered, Quaker windows are not provided with safety glass. Before ordering, consult your local building codes for more definitive information.

Fastening

- Metal fasteners and components could corrode when used with preservative-treated lumber. Use approved fasteners and components to fasten window or door. Failure to do so could cause a failure resulting in injury, product or property damage.
- Fastener must attach to a structural framing member with 1 1/2" minimum fastener embedment, or minimum 3 full threads with a minimum 5/16" head as products were tested with.
- Quaker does not supply anchorage/fastener calculations, and is not responsible for determining structural adequacy of the anchorage and fasteners used to install our products, or the openings into which they are installed.**
- Do not** over drive screws or nails. Doing so could result in product damage.

CAUTION**Installation**

- Always support window or door in opening until fully fastened. Failure to do so could result in the window or door falling out or causing injury, product, or property damage.
- Nailing flanges and drip caps (integral or applied) **do not** take the place of window flashing. All windows and doors must be properly flashed and sealed with material compatible sealant for protection against water and air infiltration around the entire perimeter. Failure to do so could result in product or property damage.
- **Do not** set window directly on sill plate. Place shims under the side jambs. Window or door must be properly shimmed. Failure to do so could affect operation and product performance and could result in product damage.
- Live or dead loads transferred into our product can affect functionality, damage frame joinery or cause glass failures. Dead loads such as upper levels, roof, etc. Should be constructed before window or door is installed.
- Loads shall be designed to withstand the most critical effects of load factors and load combinations as required by the building code. (Loads are including but not limited to Live, Dead, Collateral, Auxiliary, Thermally induced, Seismic, etc.)
- Maximum vertical deflection of the header under all Load combination should not exceed the Span/720 or 1/4" whichever is less.
- Windows and doors have small parts. Small parts if swallowed could pose a choking hazard to young children. Dispose of unused, loose, or easily removed small parts. Failure to do so could result in injury.
- **Do not** drill through or into window sill to install alarm wires.

Sealing

- Follow instructions of foam, sealant, and flashing manufacturers regarding safety, material application, compatibility, and periodic maintenance for continued weather resistance of their products. Failure to do so could result in product or property damage. **DO NOT** overfill between the frame and opening.
- Minimally expanding foam insulation must be compliant with AAMA 812-19.
- Quaker recommends 100% silicone (ASTM C920 compliant) neutral cure only sealant. Always clean all areas where sealant will be applied. Failure to do so could result in product or property damage.
- Flashing tape must meet ASTM-D779 performance requirements.
- Maintain a minimum of 1/4" between the window or door frame and exterior finish materials. Failure to do so could result in product or property damage.

Joining

- Do not join any window or door to any window or door not designed for joining. Joined windows and doors must be individually supported in the opening. Failure to do so could affect operation and product performance and could result in product or property damage.

Cleaning

- Acid solutions used for cleaning will damage glass, fasteners, hardware, and metal flashing. Protect these products and follow cleaning products manufacturers instructions. If acid contacts the window or door, wash all surfaces immediately with clean water.
- **Do not** use razor blades to clean glass surface. Glass damage could result.
- Clean glass using liquid glass cleaner.
- Clean frame, sash, panels, and insect screens using mild detergent and warm water with a soft cloth or brush.

IMPORTANT

- Buildings constructed prior to 1978 could contain lead paint which could be disturbed during window or door replacement. For more information on proper management of lead paint, go to: www.epa.gov/lead
- Care must be taken to properly recycle or dispose of old materials. Any recyclable materials should be separated from non-recyclable or hazardous materials. Please consult with local or state authorities regarding proper disposal of non-recyclable or hazardous materials.
- These are generic instructions intended to cover most common situations, which may not be appropriate for all installations due to building design, construction materials, or methods used and/or building or site conditions. Consult a contractor or architect for recommendations.
- Inspect all units for any damage or defects prior to installation. Contact the nearest Quaker distributor if there are any problems.

1

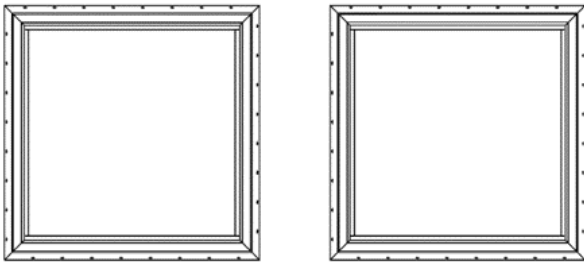

Lay the units down on a drop cloth or cardboard in the order they are to be mulled with exterior side down.

2



Using a utility knife score and remove the nailing fin from each unit where the mull will connect them. Make sure to cut the head and sill nail fins back flush with frame.

3

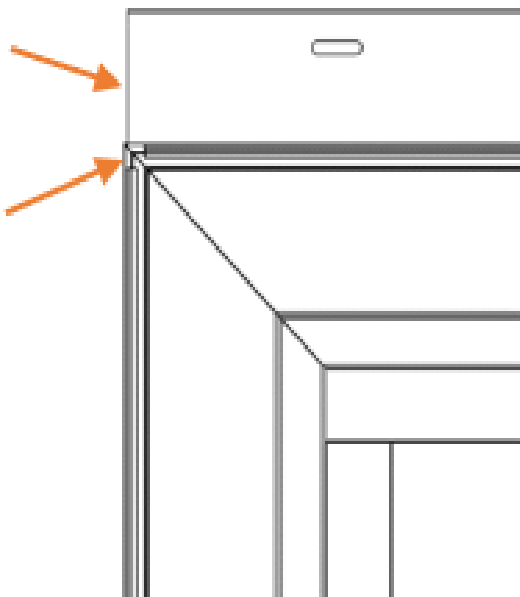

Cut a notch in the accessory channels in the head and sill to allow for mull key to set flush.

4

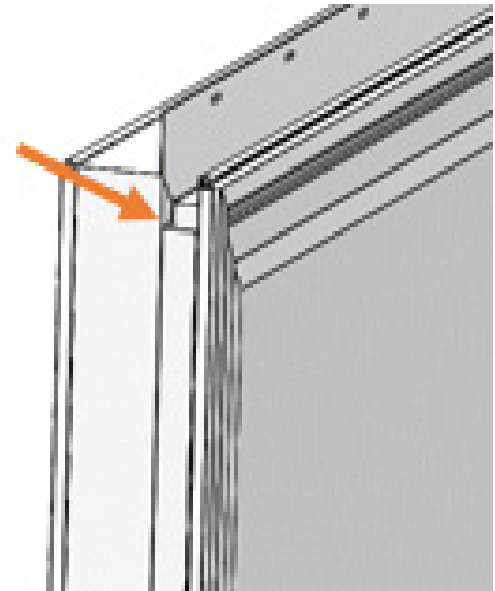

Install the j-channel filler into j-channel slot on the side to be mulled of the exterior of each window. Cut the filler short of head and sill j-channel slot so as not to obstruct the channel.

5

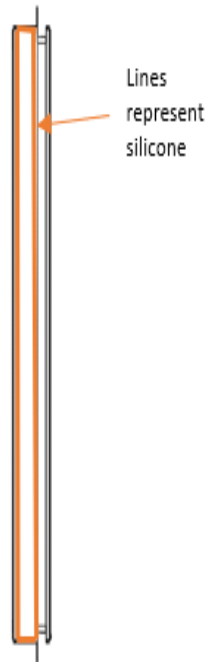

Place a continuous bead of silicone down the entire side of both windows to be mulled.

6

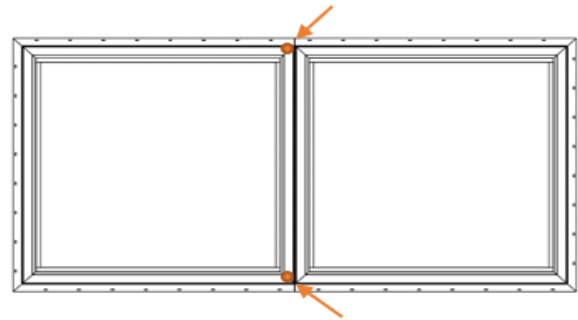

Place the windows together and add a small amount of sealant at the top and bottom of the mull channel before driving in the mulls.

7

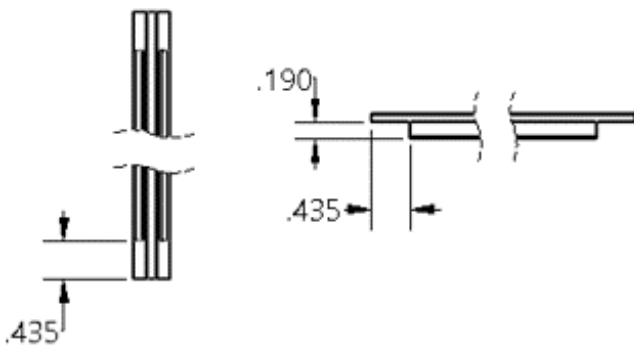

Cut the C-mull keys to the length of the unit (width or height) to be mulled.
Notch both ends of mull key with a utility knife or chisel per dimension shown above.

8

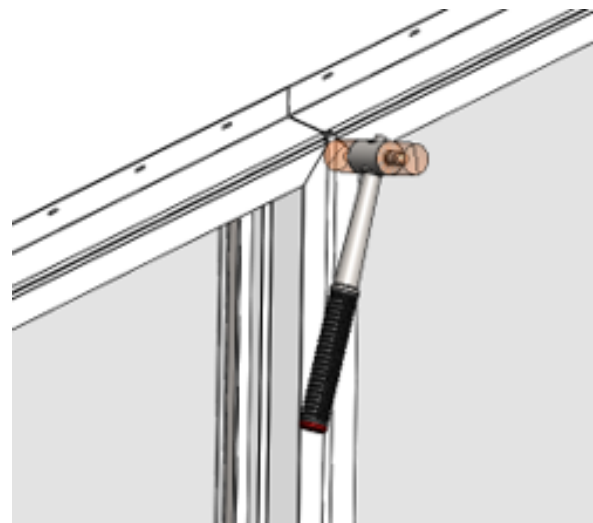

Install the mull key flush with one side of unit and hammer into place with rubber hammer.
Flip units over and repeat on other side.

9

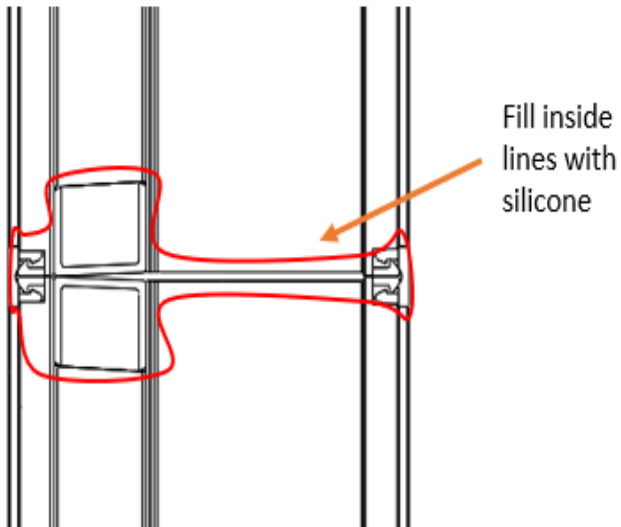

Seal both ends of the mull gap with silicone the entire width of the frame at the head and sill.

10



Install 4" piece of the jamb filler in the head and sill.

11

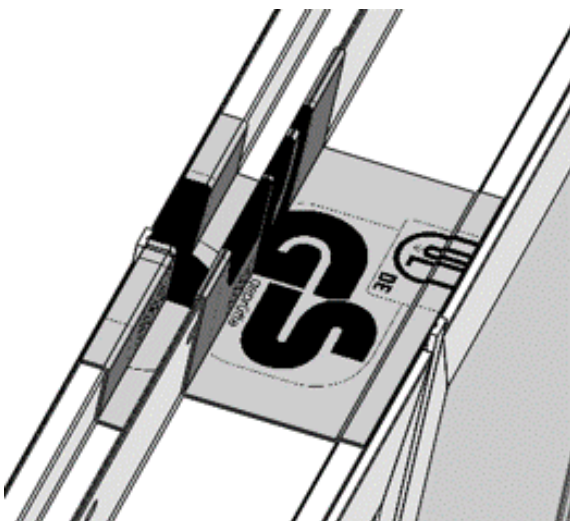

Apply self-adhesive flashing tape over the top side of mull gap and over nail fin at the head and sill.

12

Seal drip cap to window after installed with silicone.

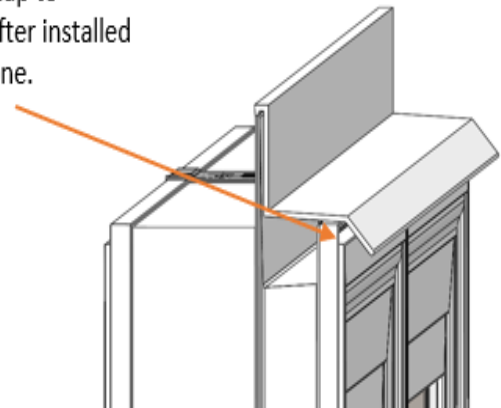

Install drip cap over the nail fin the full length of mullied units at the head.
Notch the drip cap ends if necessary for standard j-channel installation practices.